

Activity: Combinatorial Logic Circuits

A. Why?

Combinatorial logic circuits implement pure boolean functions (“pure” = “not having an internal state”).

B. Outcomes

By the end of the activity you should

- Have practiced how reading and writing diagrams using the standard gate symbols.

C. Questions

1. Take the circuit below and write out a truth table that describes what it does:

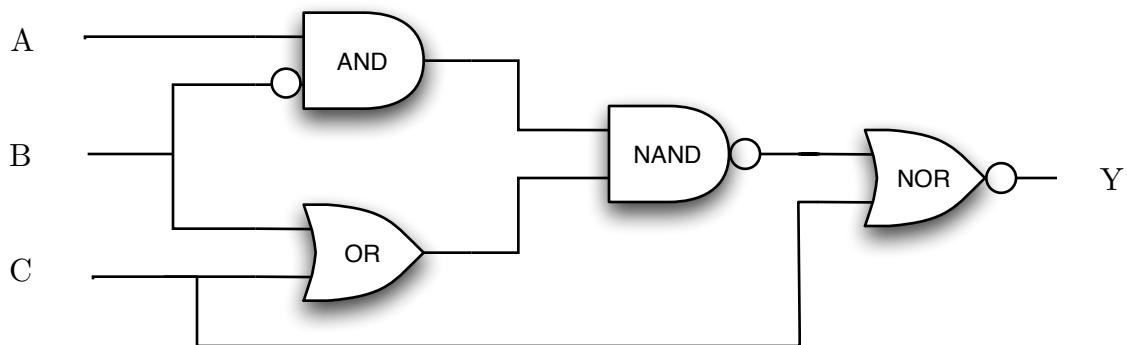

2. Draw a gate-level circuit (one using AND, OR, etc.) for the boolean function $Y = (A \text{ AND } B \text{ AND } C) \text{ OR } (\text{NOT } A \text{ AND } \text{NOT } B \text{ AND } \text{NOT } C)$. Also: Can you find a shorter English description for this function? (E.g. “3-way AND of A, B, C” isn’t quite right, since it only describes the first part of the function.)
3. (If there’s time): Draw a gate-level circuit for the carry-out bit only of a full adder that takes two bits A_i , B_i and a carry-in bit C_i . Draw a gate-level circuit for the sum bit S_i of the full adder.